

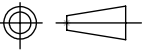

MACHINE:	260	ASME Y 14.5M 1994 APPLIES DRAWING SPECIFIES THE COMPLETE PART REQUIREMENT  THIRD ANGLE PROJECTION LINEAR TOLERANCES: X = ± 0.05 XX = ± 0.01 .XXX = ± 0.003 ANGULAR TOLERANCES ± 1° CHAMFER TOLERANCES ± 5° REMOVE ALL BURRS & SHARP EDGES .002 - .020 X 45° MAX SURFACE FINISH 125√	
POWER:	220 V. 3 Ph		
AIR PSI:	N/A		
DUST PORTS:	4" (2X)		
DUST CFM:	350		
SCALE: 1:15 DO NOT SCALE DRAWING		SIZE B PART NO. 260-1 FOOTPRINT	REV. A